

# Structures for mounting reed switches near the busbars of electrical installations with remote control of their position

Cite as: AIP Conference Proceedings **2337**, 030004 (2021); <https://doi.org/10.1063/5.0047151>  
Published Online: 08 March 2021

Zhanat B. Issabekov, Bauyrzhan E. Mashrapov, Dauren D. Issaberov, and Gulnara N. Mashrapova



View Online



Export Citation

Challenge us.

What are your needs for periodic signal detection?

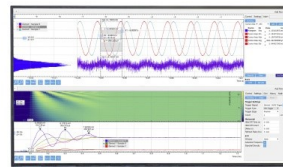

Zurich Instruments



# Structures for Mounting Reed Switches near the Busbars of Electrical Installations with Remote Control of Their Position

Zhanat B. Issabekov<sup>a)</sup>, Bauyrzhan E. Mashrapov<sup>b)</sup>, Dauren D. Issaberov and Gulnara N. Mashrapova

*Toraighyrov University, 140000, Pavlodar, Kazakhstan.*

<sup>a)</sup>Corresponding author: zh\_is@mail.ru

<sup>b)</sup>bokamashrapov@mail.ru

**Abstract.** It is noted that in relay protection resource savings can be achieved by replacing current transformers with ferromagnetic cores with miniature current sensors, such as inductance coils, reed switches, etc. It is emphasized that special designs are required for their mounting near the busbars. Models of two such designs for mounting reed switches are proposed. The first differs from the known ones by the presence of a single stepper motor connected to a microcontroller, which makes it possible to remotely move the reed switch in the horizontal plane, and the second – two electric motors, which allows you to move the reed switches in the vertical plane. At the same time, the microcontroller is located in the relay compartment of the cell of the complete switchgear, which ensures the safety of service personnel. The method of regulating the position of reed switches in space using the proposed designs is described.

## INTRODUCTION

As is known, to protect electrical installations from short circuits, relay protection devices are usually used that use current transformers with ferromagnetic cores to obtain information about the currents in their busbars [1-7]. However, these current sensors have a number of well-known disadvantages [8, 9], including metal consumption. Given that much attention has been paid to resource conservation in recent decades, replacing current transformers with more miniature current sensors could open up great opportunities in relay protection in terms of saving copper and steel. As such sensors in various publications [10-31] suggested to use magnetic current transformers, inductance coils, Rogowski coils, reed switches, etc. However, the work is far from complete. At the same time, all of them must be mounted near the busbars of protected electrical installations, which requires special designs. In this paper, we propose two such designs for mounting reed switches, which, in contrast to the known ones [32, 33], allow you to remotely change their position in space.

## STRUCTURES FOR MOUNTING REED SWITCHES

### Structure with Remote Control of the Reed Switch Position in One Plane

Figure 1 shows the first device [34] with a block for mounting reed switches in a complete switchgear (CSG). Figure 2a shows the location of three blocks for mounting reed switches in the busbar compartment of the CSG. Figure 2b shows the location of the control panel of the time-setting block and the executive body in the measurement and protection cabinet of the CSG.

The device contains three blocks for mounting reed switches and regulating their actuation current. Each block contains a plate 1, on the outer side of which six reed switches 2, 3, 4, 5, 6, 7 are fixed at different angles to the cross-sectional plane of the current-carrying busbar 8. Plate 1 is mounted to the central 9 and side 10 holders. The central holder 9 is mounted to the gear belt 11, with the ability to move along it relative to the current-carrying busbar [34].

The side holders 10 are mounted to the running axles 12. The ends of the axles 12 are mounted to the first 13 and second 14 support posts fixed on the lower base of the busbar compartment of the CSG using a mounting angle 15, screws 16 and a bolted connection 17. On the first post 13, a stepper motor 18 and a winding mechanism 19 are mounted. The first gear pulley 20 and coupling 21 are mounted to the stepper motor 18. On the second support post 14, a second gear pulley 22 is fixed, mounted by means of a mounting plate 23. On the first 20 and second 22 gear pulleys the gear belt 11 is put on. One of the contact cores of reed switches 2, 3, 4, 5, 6, 7 connected to the time-setting block 24 by means of a first connecting cable 25, which is mounted at one end to plate 1, laid in the air to the winding mechanism 19, from winding mechanism 19 to the first support post 13 to lower the base busbar compartment of the CSG, from lower the base busbar compartment of the CSG and then put in a plastic sleeve 26, laid along the lower base and rear wall of the busbar compartment of the CSG to the block 24, to which the other end of the first connecting cable 25 is connected.

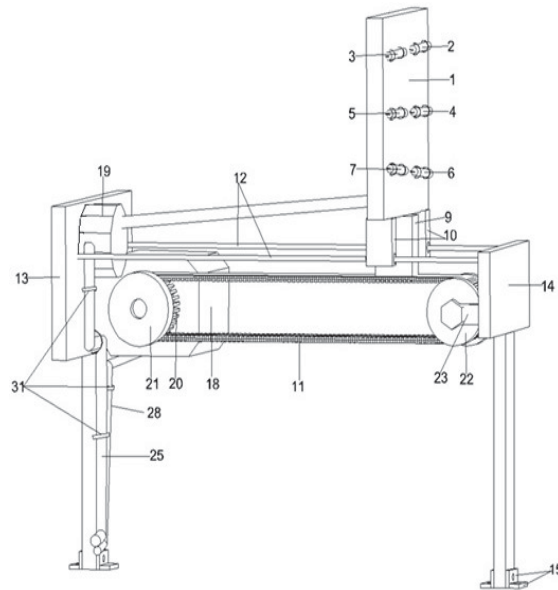

**FIGURE 1.** Block for Mounting Reed Switches

Other contact core of reed switches 2, 3, 4, 5, 6, 7 using the cable 25 is connected to the output of the automatic switch 27 with the "plus" sign. The stepper motor 18 of each of the three blocks for mounting reed switches and regulating their actuation current using a second connecting cable 28 is connected to the control panel 29 with a touch screen 30. A second connecting cable 28 is laid on the first support post 13 to lower the base busbar compartment of the CSG, on the lower base of the busbar compartment of the CSG and filed in a plastic sleeve 26. The first 25 and second 28 connecting cables and the sleeve 26 are mounted to the post 13, the lower base and the wall of the busbar compartment of the CSG using plastic clamps 31. The first and second inputs of the control panel 29 are connected via wires 32 to the outputs of the automatic switch 27 with the signs "plus" and "minus", respectively. The executive body 33 is connected via wires 34 with one input to the output of the time-setting block 24, and the other to the output of the automatic switch 27 with a "minus" sign. To seal the entrances and exits for plate 1 a rubber gasket 35 is used (Fig. 2a); for the control panel 29 – rubber gaskets 36, 37; for the block 24 – rubber gaskets 38-40; for the executive body 33 – rubber gaskets 41 (Fig. 2b). The block 24, the automatic switch 27, the control panel 29, and the executive body 33 are located in the measurement and protection cabinet of the CSG [34].

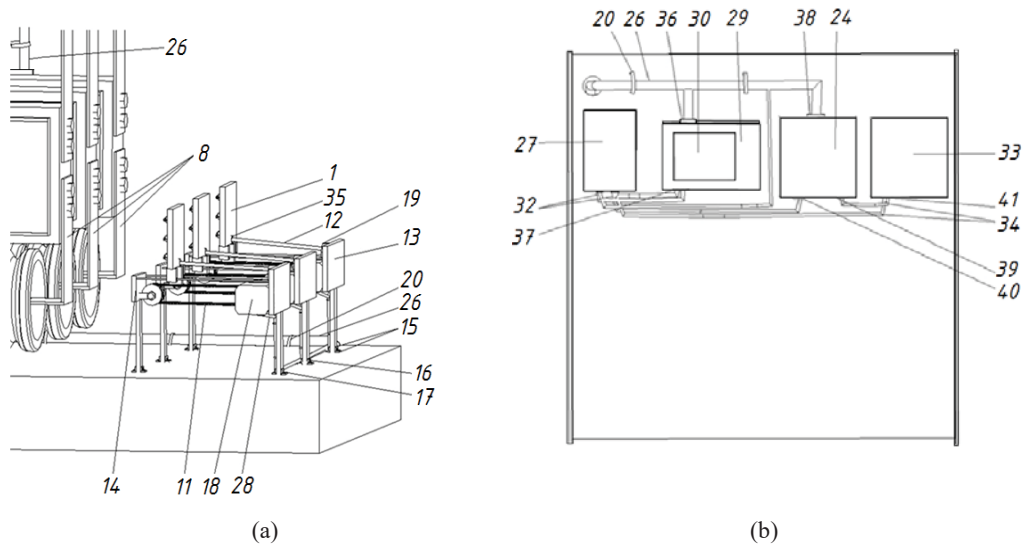

**FIGURE 2.** Compartments of the complete switchgear: (a) – bus compartment with three blocks for fastening reed switches; (b) – relay compartment with control unit

As reed switches 2, 3, 4, 5, 6, 7 reed switches of the MKA-20 type can be used, cables 25, 28 – cables of the Olflexclassic 100 4\*1.5 and Olflexclassic 100 8\*1.5 brands, wires 32, 34 – wire of the PV-1\*6 brand. As a stepper motor 18 an engine of the SL42STH48-1504A type can be used, and an automatic switch 27 – a switch of the AP-50 type. All structural elements, except for the stepper motor, mounting angle, screws and bolted connection are made of non-magnetic material [34].

Consider, for example, the protection of the VAO-5000-2 UHL4 electric motor, with a capacity of 5 MW, connected to the K-63-10 CSG cell, made using a reed switch 2 located to the cross-sectional plane of the current-carrying busbar 8 at an angle of  $0^{\circ}$  degrees. The remaining five reed switches located on plate 1 are designed to provide a more accurate selection of setpoints and will be used if it is not possible to select the reed switch 2 with the necessary magnetomotive force [34].

In the rated load mode, a current flows through the protected electrical installation that does not exceed the maximum operating current, and the reed switches 2, 3 and 4 are affected by a magnetic field whose induction value is insufficient for their actuation, and the protection does not work. If a short circuit occurs at the terminals of the protected electrical installation, the current in the current-carrying busbars 8 becomes greater than the protection actuation current. Therefore, one of the reed switches closes its contacts and sends a signal to the input of the time-setting block, which, after a time delay, sends a signal to the input of the executive body. The executive body is triggered and sends a signal to turn off the switch of the electrical installation [34].

If a short circuit occurs at the terminals of the protected motor, the current in the current-carrying busbars 8 becomes greater than the protection actuation current. Therefore, the reed switch 2 closes its contacts and sends a signal to the input of the time-setting block 24, which, after a time delay, sends a signal to the input of the executive body 33. The executive body 33 is triggered and sends a signal to turn off the electric motor switch [34].

### Structure with Remote Control of the Reed Switch Position in Two Planes

In order to expand the range of control parameters for the actuation of the measuring protection body and to ensure its more precise control, a design was developed [35] for mounting reed switches, which allows them to be moved both in the horizontal and vertical planes. It contains three mounting blocks. Each block contains a plate 1 (Fig. 3a), on the outer side of which three reed switches 2, 3, 4 are mounted using the first bolts 5 to the terminal block 6, at different angles to the cross-sectional plane of the current-carrying busbar 7, electric motors 8 and 9, drive shafts 10 and 11. The electric motors 8 and 9 are connected to the drive shafts 10 and 11 by means of couplings 12 and 13. The plate 1 is moved using the drive sleeve 14. The plate 1 with the lugs 15 installed on it, through which the running axes 16 and 17 pass, is mounted to the drive sleeve 14 by means of a holder 18. The sleeve 14 is connected by means of a holder 18 to the drive shaft 10 with the possibility of moving along it to the limiting stop 19. The beginning and ends of the running axes 16 and 17 are mounted to the supporting bars 20 and

21, and the beginning and ends of the running axles 22 and 23 are mounted to the supporting bars 24 and 25. The beginning and ends of the running axles 16, 17, 22 and 23 are mounted to the supporting bars 20, 21, 24 and 25 on their inner side using washers 26, 27, 28, 29, and on the outer side – using bolts 30, 31, 32, 33. Electric motors 8 and 9 are mounted on the support bars 20 and 21 using bolts 34 and 35; on the support bar 25 – a hollow cylinder 36, as well as the ends of the running axles 22 and 23. On the holder 37 with the lugs 38 installed on its sides, through which the axles 22 and 23 pass, a bar 20 is mounted. On the bar 20 an electric motor 8, a drive shaft 10 and a plate 1 are installed with lugs 15 mounted on it, attached to the sleeve 14 using a holder 18. The limiting stop 19 is mounted to the shaft 10 using a bolt 39. The supporting bar 20 moves along the drive shaft 11 using the drive sleeve 40 when the electric motor 9 is turned on. The hollow cylinder 36 is connected to the drive shaft 11. The holders 18 and 37 are mounted to the drive sleeves 14 and 40 by bolts 41. A microcontroller is available to control the movement of electric motors 8 and 9.

The number of revolutions of electric motors 8 and 9 clockwise or counterclockwise is set in the microcontroller program. Regulation of the maximum current protection actuation current is carried out by transverse and longitudinal movement of the plate 1 with reed switches 2, 3 and 4 to or from the current-carrying busbar 7 in the busbar compartment of the CSG cell using electric motors 8 and 9. The supporting bars 24 and 25 are mounted to the lower base of the busbar compartment of the CSG using a mounting angle 42 and screws 43. The outputs of the reed switches are connected to the input of the time-setting block, the output of which is connected to the input of the executive body. The output of the latter is in the circuit breaker disconnection.

Regulation of the parameters of the maximum current protection against short circuits is carried out by approaching the current-carrying busbar 7 of the plate 1 with reed switches 2, 3 and 4 of each phase (Fig. 3a). One of three reed switches is used for one protection. In the busbar compartment of the CSG at a safe distance of 0.12 m from the current-carrying busbars 7, three blocks for mounting reed switches and regulating their actuation current are installed, a time-setting block and an executive body are connected [35].

Transverse movement of the plate 1 with reed switches 2, 3 and 4 to the current-carrying busbar 7 (Fig. 3b) in the CSG is performed by turning on the electric motor 9 (Fig. 3a), fixed to the supporting bar 24 using bolts 35, in a clockwise or counterclockwise direction. In this case, the holder 37 moves along the second drive shaft 11 in the direction to or from the busbar 7 using the drive sleeve 40. On both sides of the holder 37, lugs 38 are installed, through which the running axles 22 and 23 pass when moving, and a supporting bar 20 is mounted to the holder 37. The plate 1 is moved in the direction of the current-carrying busbar 7 to the hollow cylinder 36, and in the direction from the busbar 7 to the coupling 13 [35].

The longitudinal movement of the plate 1 with reed switches 2, 3 and 4 along the busbar 7 is performed by turning on the electric motor 8, fixed to the supporting bar 20 using bolts 34, in a clockwise or counterclockwise direction. In this case, the plate 1 with reed switches 2, 3 and 4 moves up and down the drive shaft 10 by means of the drive sleeve 14. On both sides of this plate 1 lugs 15 are installed, through which the running axles 16 and 17 pass when moving. The plate 1 is moved in the upper part to the limiting stop 19, and in the lower part to the coupling 12 [35].

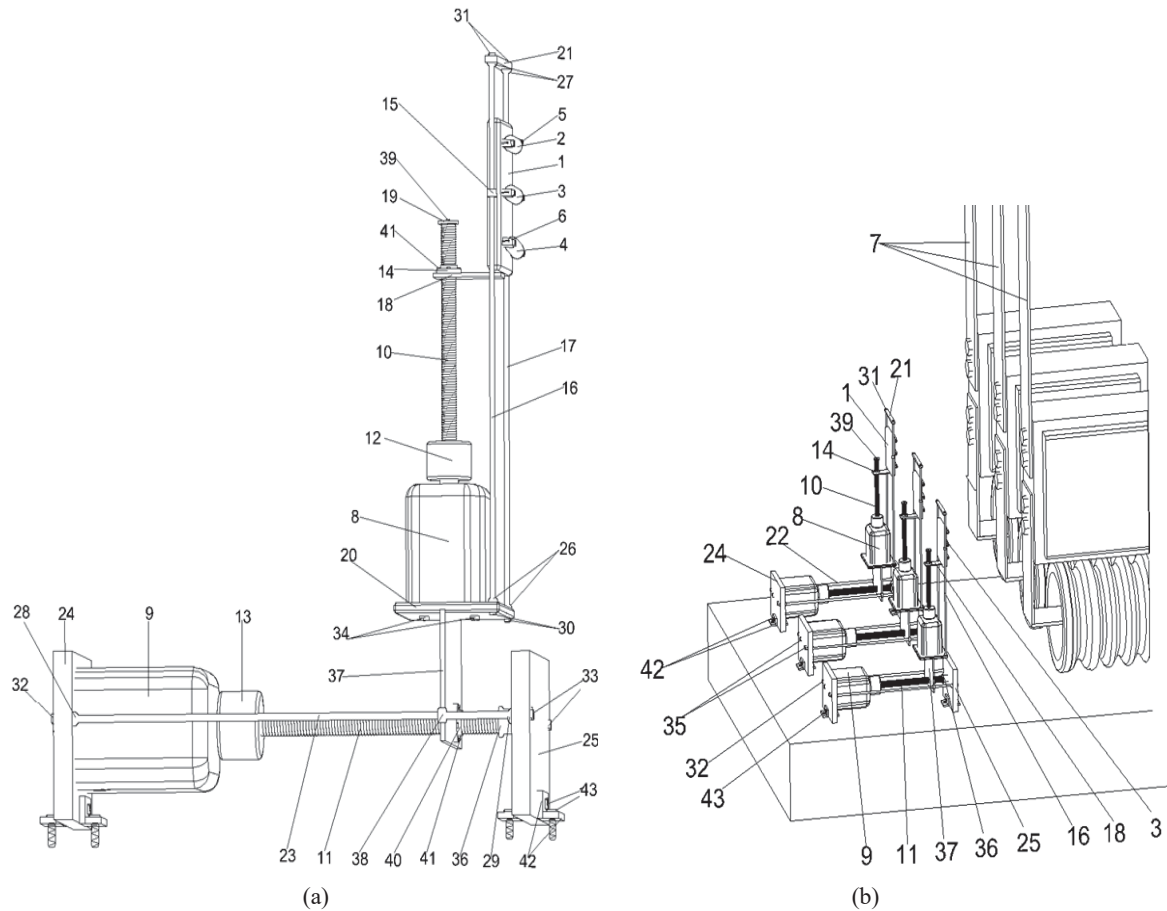

**FIGURE 3.** The structure for mounting reed switches (a) and its placement in the busbar compartment of the CSG (b)

Before installing the design for mounting reed switches in the CSG cell, calculate the distance and angle at which reed switches 2, 3 and 4 should be located in relation to the magnetic field lines created by the current in the busbar 7, and also calculate the value of the maximum current protection actuation current in the busbar 7, at which the protection should work. Then, according to tabular data, reed switches 2, 3 and 4 with a given magnetomotive force are taken [35].

## CONCLUSIONS

1. The proposed designs allow to save copper and steel in the construction of relay protection devices against short circuits of CSG cell connections due to the absence of metal-intensive current transformers with a ferromagnetic core.

2. The developed designs allow to change the position of reed switches in space remotely, which makes it possible to adjust the parameters of protection actuation without disconnecting the electrical installation from the network, and also increases the electrical safety of service personnel.

## ACKNOWLEDGMENTS

Study was financially supported by the Science Committee of the Ministry of Education and Science of the Republic of Kazakhstan (Grant No. AP05131351).

## REFERENCES

1. V. A. Andreyev, *Relay protection and automation of power supply systems* (Higher School, Moscow, 2006) p. 639.
2. M. Kletsel and B. Mashrapov, *Prz. Elektrotech.* **92** (2), 109–112 (2016).
3. A. N. Novozhilov and M. P. Volikova, *Russ. Electr. Eng.* **77** (4), 6–14 (2006).
4. A. V. Bogdan, M. Y. Kletsel', and K. I. Nikitin, *Elektrichestvo* **2**, 51–54 (1991) [in Russian].
5. M. Y. Kletsel' and K. I. Nikitin, *Elektrichestvo* **2**, 19–22 (1992) [in Russian].
6. M. Y. Kletsel' and K. I. Nikitin, *Elektrichestvo* **3**, 23–26 (1993) [in Russian].
7. M. Kletsel and B. Mashrapov, *Prz. Elektrotech.* **93** (10), 109–112 (2017).
8. L. A. Kojović, *CIGRE Session* **46**, B3-101\_2016 (2016).
9. M. Ya. Kletsel, "Basics of construction of relay protection on reeds," in *Modern Development of Relay Protection and Power System Automation Systems* (Ekaterinburg, 2013), pp. 1-10.
10. V. E. Kazansky, *Measuring current transformers in relay protection* (Energy, Moscow, 1978) p. 264.
11. V. N. Grechukhin, V. N. Nuzhdin, V. V. Gluskina, I. A. Novozhilov, and K. S. Dmitriyev, *Energetik* **6**, 14–16 (1997) [in Russian].
12. N. I. Ovcharenko, V. G. Doroguntsev, E. I. Bass, and V. V. Budkin, *Application of galvanomagnetic elements in relay protection and automation* (Energy, Moscow-Leningrad, 1966), p. 120.
13. I. M. Sirota, *Elektrichestvo*, **4**, 22–24 (1967) [in Russian].
14. M. Kletsel, V. Borodenko, A. Barukin, A. Kaltayev, and R. Mashrapova, *Rev. Roum. Sci. Tech-El.* **64** (4), 309–315 (2019).
15. M. Ya. Kletsel, *Elektrotehnika* **10**, 47–50 (1991) [in Russian].
16. M. Ya. Kletsel, V. V. Musin, Zh. R. Alishev, and A. V. Manukovskij, *Elektrichestvo* **9**, 18–21 (1993) [in Russian].
17. M. Kletsel, A. Barukin, and O. Talipov, *Prz. Elektrotech.* **93** (11), 129–132 (2017).
18. M. Kletsel, A. Zhantlesova, P. Mayshev, B. Mashrapov, and D. Issabekov, *Int. J. Electr. Power Energy Syst.* **101**, 85–91 (2018).
19. A. B. Zhantlesova, M. Y. Kletsel, P. N. Maishev, and A. V. Neftisov, *Russ. Electr. Eng.* **85** (4), 210–216 (2014).
20. M. Ya. Kletsel and M. A. Zhulamanov, *Elektrotehnika* **5**, 38–44 (2004) [in Russian].
21. M. Ya. Kletsel and P. N. Maishev, *Russ. Electr. Eng.* **78** (12), 629-634 (2007).
22. A. Barukin, A. Berguzinov and O. Talipov, "Mounting Measuring Devices of Reed Switch Protection Near Conductors of Electrical Installations," in *2020 International Multi-Conference on Industrial Engineering and Modern Technologies* (Vladivostok, 2020).
23. M. Kletsel, A. Barukin, and D. Amirbek, "Reed Switch and Magneto Resistor-Based Differential Protection Featuring Test Diagnostics for Converters," in *2020 International Multi-Conference on Industrial Engineering and Modern Technologies* (Vladivostok, 2020).
24. M. Kletsel, N. Kabdualiyev, B. Mashrapov, and A. Neftisov, *Prz. Elektrotech.* **90** (1), 88–89 (2014).
25. M. Kletsel, A. Kaltayev, and B. Mashrapov, *Prz. Elektrotech.* **93** (5), 40–43 (2017).
26. A. Barukin, A. Kaltayev, and Y. Lenkov, "Majority Voting Schemes of Differential Protections without Current Transformers with Functional Diagnostics for Converting Units and Electric Motors," in *2020 International Conference on Industrial Engineering, Applications and Manufacturing* (Sochi, 2020).
27. B. Mashrapov, "Improving the Reliability of Diagnosing Reed Switch-Based Overcurrent Protection Circuits," in *2020 International Multi-Conference on Industrial Engineering and Modern Technologies* (Vladivostok, 2020).
28. M. Y. Kletsel', A. V. Neftisov, and P. N. Maishev, *Russ. Electr. Eng.* **91**, 34–40 (2020).
29. M. Kletsel, R. Mashrapova, and B. Mashrapov, "Methods for the Construction of Protection with Magnetosensitive Elements for the Parallel Circuits with Single end Supply," in *2020 International Conference on Industrial Engineering, Applications and Manufacturing* (Sochi, 2020).
30. M. Kletsel, A. Barukin, and A. Gabdulov, "Construction of Resource-Saving Differential Protections for Converter Units with Transformers with 2N Secondary Windings and 2N Rectifiers," in *2020 International Ural Conference on Electrical Power Engineering* (Chelyabinsk, 2020), pp. 264-268.

31. B. Mashrapov, O. Talipov, and R. Mashrapova, "Overcurrent Protection Scheme Utilising Reed Switches Instead of Current Transformers," in *2020 International Ural Conference on Electrical Power Engineering* (Chelyabinsk, 2020), pp. 291-295.
32. M. Kletsel, A. Barukin, and B. Mashrapov, "Designs for Mounting Reed Switches in Vicinity of AC and DC Buses," in *2020 International Ural Conference on Electrical Power Engineering* (Chelyabinsk, 2020), pp. 285-290.
33. A. Kaltayev, B. Mashrapov, and O. Talipov, "Designs for Mounting Reed Switches in Closed Complete Current Conductors and on Cable Lines," in *2020 International Conference on Industrial Engineering, Applications and Manufacturing* (Sochi, 2020).
34. M. Ya. Kletsel, K. I. Nikitin, B. E. Mashrapov, and D. D. Issabekov, Pat. RU 2678189 (2019).
35. M. Ya. Kletsel, V. A. Borodenko, and D. D. Issabekov, Pat. KZ 34366 (2020).